

Polycom® RealPresence™ Experience High Definition (RPX™ HD)

The world's premier immersive telepresence solution



The Polycom RealPresence Experience High Definition offers unprecedented high-definition video in a cinematic view, extraordinary StereoSurround™ audio and high resolution content in a truly immersive environment that will provide the ultimate meeting experience for anyone in any organization, linking sites across the globe.

 **POLYCOM®**
TOGETHER, GREAT THINGS HAPPEN.

VideoVoiceDataWeb



Introducing the most effortless way to conduct video communications

Imagine walking into a comfortable, luxurious meeting environment, taking a seat and starting a real-live conversation with your counterparts from across the world. There's no technology in the way and you are focused on the discussion at hand. Welcome to the world of Polycom RealPresence Experience High Definition.

Polycom RPX HD offers:

Transparent technology for a more comfortable meeting environment. The Polycom RPX HD removes the cameras, microphones, speakers, remote controls and other technology from the user's view so there are absolutely no distractions. The result is an uncluttered, welcoming immersive suite in which to have a productive meeting.

Complete interoperability with other video communications solutions. The Polycom RPX HD is standards-based and will allow multiple participants to join a call from rooms with high definition as well as traditional, standard definition, video conferencing systems. Paired with managed services, the multipoint possibilities are virtually endless.

Large format, seamless visual displays. The Polycom RPX HD video participants are shown in high definition, true-life dimensions on multiple, seamless displays at the front of the room. In the Polycom RPX HD 400 Series Suites, experience 48x9 format for a truly amazing cinematic experience.

An all inclusive environment: Polycom RPX HD is a complete video suite with all the furnishings, studio lighting, acoustic cloud and walls and electronics; a true room-within-a-room. Because the suite is modular and does not attach to the physical room, this solution is easily installed and can be moved to a new facility as your organization expands.

Multiple, flexible configurations to suit your application. The Polycom RPX HD Suites are available in multiple configurations with an offering of varying design finishes. An organization can then standardize on a consistent design and build a room that fits the facility and the applications. Optional peripherals and customization offer expanded flexibility.

Extraordinary audio and video quality in a telepresence setting. With the implementation of Polycom's UltimateHD™ video resolution of up to 3820 x 720p and StereoSurround using 22 kHz audio, there is no better immersive room experience than the Polycom RPX HD. You'll see every detail from the far end on large-as-life video displays and experience spatial audio from the combination directional ceiling microphones and stereo speakers.





Polycom RPX HD is an all-inclusive suite that comes complete with every environmental element and integrated technology required to create the Polycom immersive telepresence experience.

- Seamless 24:9 video wall creates an intimate face-to-face experience in the RPX 200 Series Suites
- Full screen, cinematic view in the RPX 400 Series Suites facilitates large group meetings
- Polycom HDX 9004 UltimateHD video conferencing solutions built-in
- Polycom SoundStation VTX 1000® wideband conference phone for audio-add participants
- Mini 3-CCD high definition video cameras embedded (out of view) behind the video wall that enables natural eye contact in group settings
- Stereo speakers mounted above the video wall (out of view) that deliver StereoSurround in 22 kHz audio
- Touch control panel facilitates an in-room administrator to control audio and video dialing as well as volume control and a direct link to the managed services help desk
- Unobtrusive, ceiling mounted digital microphones for multi-directional, 360 degree voice pickup
- Direct VGA connectivity for laptops facilitate sharing of content in a moment's notice
- Integrated, 15" high resolution content displays are within arms reach of every participant so that everyone is involved in the meeting
- Network access and power connections accessible to every seat to accommodate knowledge worker's laptops
- Studio quality lighting built-in to the ceiling cloud with 45 degree gated louvers ensure that lighting is favorable on all participants
- Acoustic batting is installed throughout the suite to ensure that ambient noise is blocked out so that meetings can carry on without distractions
- Multipurpose conference table can be used to seat extra participants when the suite is not being used for video communications
- Raised, expansion seating accommodates larger group meetings when important decisions are to be made

Polycom RPX HD is available in multiple seating configurations to best meet your organization's needs.

Model	Number of Contiguous Video Displays	Number of Personal Content Displays	Seats Facing Forward	Additional Seats
Polycom RPX HD 204	2	2	4	0
Polycom RPX HD 204M	2	4	4	4
Polycom RPX HD 208M	2	6	8	4
Polycom RPX HD 210M	2	7	10	4
Polycom RPX HD 210M+	2	7	10	4
Polycom RPX HD 218M	2	11	18	4
Polycom RPX HD 408M	4	8	8	8
Polycom RPX HD 418M	4	14	18	8
Polycom RPX HD 428M	4	20	28	8

We understand the varied requirements for a multi-national organization relative to facilities management, workforce dynamics and communications requirements. This is why Polycom offers several Polycom RPX HD configurations. We understand that one room size won't necessarily fulfill every business need and we will offer guidance in choosing the configuration that is right for you.



Polycom RPX HD 400 Series



The Polycom RealPresence Experience High Definition is available in a variety of floor plans to fit virtually any application.

All of these configurations include all of the furniture, ceiling cloud with studio lighting, stereo sound system, walls, front video wall, dark room with electronic components and conference table with conference phone and touch panel control, all packaged as a single, orderable part number.

Polycom RPX HD 204

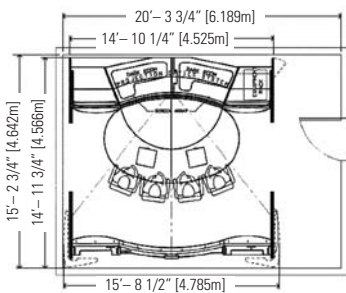

Polycom RPX HD 204M

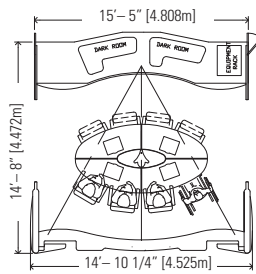

Polycom RPX HD 208M

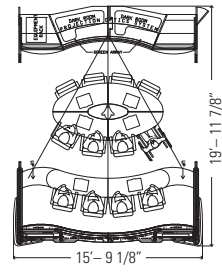

Polycom RPX HD 210M

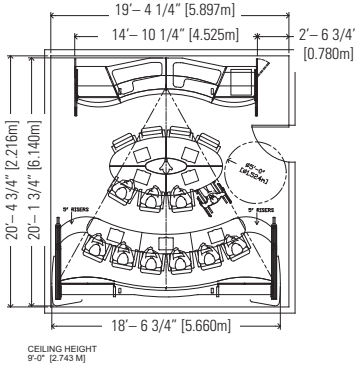

Polycom RPX HD 210M+

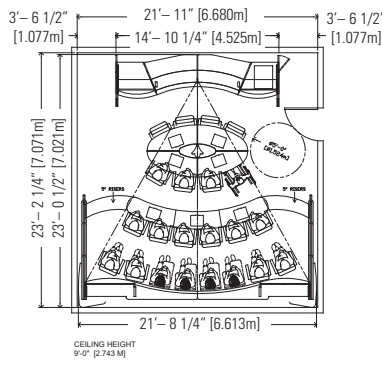

Polycom RPX HD 218M

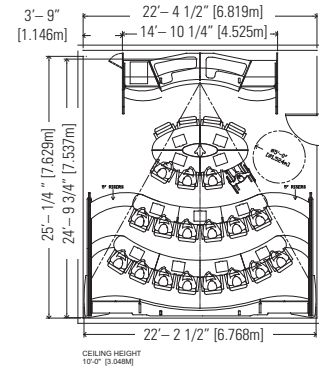

Polycom RPX HD 408M

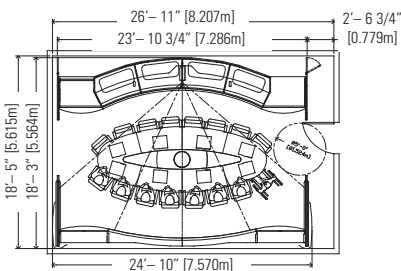

Polycom RPX HD 418M

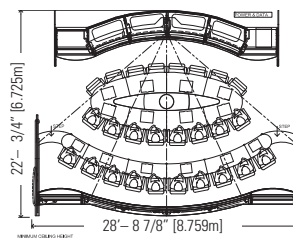

Polycom RPX HD 428M

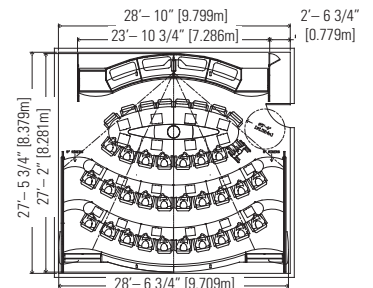

Polycom Global Services provides high-touch offerings to ensure that your Polycom RPX HD telepresence experience is exceptional.

Polycom RPX HD Implementation Services

It all starts with good planning and knowledgeable experts. An assigned project manager works hand-in-hand with you to ensure that the room designated as the telepresence location is optimized for installation. This qualification process includes a thorough on-site pre-installation survey that is performed by a senior RPX field engineer. The on-site survey is followed by the development of detailed CAD drawings that show exact placement of the Polycom RPX HD suite, and serves as a “make ready” document that illustrates any facility changes that are required to begin the installation process. Once the telepresence solution arrives at your location, a team of specialists is dispatched to begin the assembly process, perform extensive testing, verify configuration, gain customer acceptance of the installation, and provide orientation sessions for your employees.

Polycom RPX HD Maintenance Services

Maximize the availability and effectiveness of your installed telepresence solution by taking advantage of the extensive post-sales support offerings for the Polycom RPX HD Suite. Services include:

- Unlimited 24x7 technical support
- Engineering escalation support
- On-site support with next day response*
- Advance parts replacement for technology components
- Parts replacement for Polycom RPX HD Suite furnishings
- Software upgrades and updates to technology components**

As a preventative maintenance measure, a certified technician will conduct an on-site visit once every six months to check the suite and verify that all technology components are aligned and in good working order.

Polycom RPX HD Video Network Operations Center

Experience concierge level service for all of your RPX HD conferences by leveraging our VNOC solution. Our VNOC service provides complete hosted management of your RPX HD Suite through a staff of telepresence experts.

This service includes:

- Complete call scheduling and suite reservation assistance
- Call Management
- Remote call launching
- Comprehensive fault management
- Monitoring of conferences
- Monthly reports on key operational data

This “white-glove” treatment ensures that your telepresence meetings are always connected on time, and that the technology becomes virtually transparent to the meeting participants.



Polycom RPX HD Video Network Operations Center (VNOC)

**Geographical dependency in certain areas — check with local Polycom Sales Representative for availability*

*** When available*

Join Polycom in this exciting emergence of telepresence

Telepresence is the relatively new phenomenon of video communications that envelops the participants in a luxurious, comfortable environment where the technology is transparent and the high definition video clarity is so sharp that the far end participants appear to be just across the table. The eye-to-eye contact is amazingly real, and the spatial audio causes heads to turn, almost unconsciously, to face the speaker. Plus, the managed services supporting the suite mean that calls are always connected on time, and you don't have to do any of the work.

As organizations become more diverse in business applications, acquisitions and mergers become more commonplace and multi-national work forces become the standard, decision makers are looking for ways to make communicating among their knowledge workers effortless. Gone are the days of extended travel, waiting in long airport security lines, travel delays, inflated travel budgets and lost productivity.

Polycom RPX HD Suites solve multiple challenges for an organization:

- Executives, Boards of Directors and subject matter experts use their time in meetings more effectively because their focus is on the discussion at hand, not the technology
- Productivity is increased because workers spend more time working and less time traveling
- Business relationships develop and become more solid through continual, face-to-face telepresence communications
- Sharing of ideas across distances is enhanced through content sharing and collaboration in conjunction with a real-life video presence
- Limited financial and human resources that were spent on travel can be channeled into more productive efforts that will promote the value of the organization
- Video communications has become an acceptable, productive means to connect with dispersed team members and actually encourages more frequent collaboration
- Project teams experience accelerated decision making and reduced time to market with new products
- The quality of life for an organization's most valuable resource, its people, is preserved and results in greater employee retention

Why Polycom?

As the worldwide leader in video, voice, data collaboration and Web solutions, Polycom has a strong history of producing high-quality products, offering award winning services and has longstanding strategic development partnerships that further the usability of our products. If your organization has an existing deployment of traditional video conferencing equipment, the Polycom RPX HD Suites are completely interoperable and will provide extended usability of your existing equipment investment. For many organizations, this is a significant capital investment.

Polycom's network of Certified RPX Channel Partners worldwide are well qualified and specifically trained to sell, install and support the Polycom RPX HD solutions. This will be a great asset to multi-national organizations as telepresence is deployed and the way you work is dramatically improved with the Polycom RealPresence Experience.

Make Great Things Happen With Polycom RPX HD Solutions

In today's Internet driven world, the ability to conduct real time communication and collaboration has become critical to an organization's survival. As the market leader in voice, video, data and Web solutions, our award-winning conference technology makes it easy for people to interact and maximize productivity – over any network, in just about any environment, anywhere around the globe. That's why more organizations worldwide use and prefer Polycom conferencing solutions. Because when people work together, great things happen. See how you too, can achieve great things with Polycom RPX HD solutions.

©2007 Polycom, Inc. All rights reserved.

Polycom, the Polycom logo and SoundStation VTX 1000 are registered trademarks and RealPresence, RPX, StereoSurround and Polycom UltimateHD are trademarks of Polycom, Inc. in the U.S. and various countries. All other trademarks are the property of their respective owners. Information in this document is subject to change without notice.



Polycom Headquarters:

4750 Willow Road, Pleasanton, CA 94588 (T) 1.800.POLYCOM (765.9266) for North America only.
For North America, Latin America and Caribbean (T) +1.925.924.6000, (F) +1.925.924.6100

Polycom EMEA:

270 Bath Road, Slough, Berkshire SL1 4DX, (T) +44 (0)1753 723000, (F) +44 (0)1753 723010

Polycom Asia Pacific:

8 Shenton Way, #11-01, Singapore 068811 (T) +65.6389.9200, (F) +65.6323.3022, (F)+852.2866.8028

Part No. 3726-17534-001 Rev. 10/07